

The GENERAL RADIO EXPERIMENTER

VOL. 3 NO. 6

NOVEMBER, 1928

The General Radio Experimenter is published each month for the purpose of supplying information of particular interest pertaining to radio apparatus design and application not commonly found in the popular style of radio magazine.



There is no subscription fee connected with the General Radio "Experimenter." To have your name included in our mailing list to receive future copies, simply address a request to the GENERAL RADIO CO., Cambridge, Mass.

J. W. HORTON OUR NEW CHIEF ENGINEER

It is with great pleasure that we welcome to the General Radio staff J. Warren Horton, who has just joined as Chief Engineer. Mr. Horton comes to us after a twelve-year association with the Bell Telephone Laboratories.

After graduating from the Massachusetts Institute of Technology in 1914, Mr. Horton remained for two years as an instructor in Physics, going from there to the research department of the Western Electric Company, now known as the Bell Telephone Laboratories and located in New York City.

A vast variety of problems have occupied Mr. Horton's attention. His work includes submarine-detection devices, precise frequency-standardization apparatus, the transmission of pictures by wire, television, as well as the manifold problems associated with carrier-frequency telegraphy and telephony.

Mr. Horton has been granted many patents and is the author of many technical articles which have appeared in scientific journals.

Rating of Radio Receivers

As the manufacture of radio equipment settles down to a stabilized industry, quantitative ratings are looked for with which to describe such equipment in a manner similar to that used for other electrical and mechanical apparatus. The inadequacy of such ratings as "coast-to-coast reception every night" becomes apparent as the Barnum era passes. At first the usual methods of rating electrical machinery in kilowatts or kilowatt hours do not seem applicable to such a device as a radio instrument. Actually, however, a radio receiver is a power converter, and its output is logically expressed in terms of power, but in milliwatts rather than in kilowatts. Obviously, a rating in terms of output power is a very incomplete description of a radio receiver, since it has no reference to the signal intensity in the antenna required to give the rated output. In order to describe the instrument completely (so far as sensitivity goes), a relation between input voltage and output power must be derived. This might be expressed as a ratio, but, in order to simplify the relation, a standard output has been agreed upon which permits a receiver to be rated in microvolts required to give

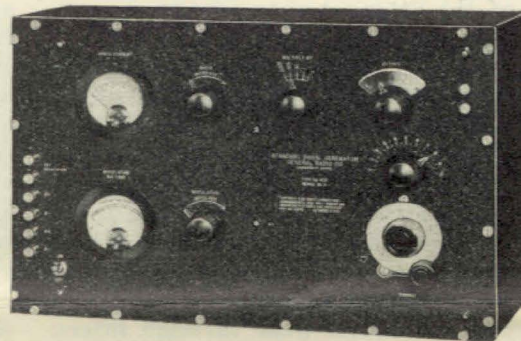

TYPE 403 STANDARD-SIGNAL GENERATOR

standard signal, or, more simply, as possessing a sensitivity of so many microvolts, standard output being assumed.

The arbitrary figure of 50 milliwatts has been tentatively agreed upon as the standard output (I. R. E., Preliminary Report of Committee on Standardization, May, 1928) and the microvolt becomes the unit of sensitivity on this basis.

In order to measure the sensitivity of a receiver in microvolts, it is necessary to introduce into the receiver a signal sufficient to give the standard output, and to determine the strength of this signal in microvolts. The measurement of voltages of a few microvolts is not a matter of attaching

a voltmeter of proper range, and reading the scale. The simplest method of determining voltages of this order is by putting a known current through a known resistance. It is essential that the voltage be impressed entirely at one point, i. e., the antenna and ground posts of the receiver. If there is any stray field from the voltage source, large errors will be introduced. Thus, there is required for these measurements a local signal generator so designed that a known minute radio-frequency voltage may be produced between two designated terminals and nowhere else. With such a device, over-all measurements, either of the entire radio-frequency amplifier or of the whole receiver, may be taken. The single unit should contain both the source of voltage and the means for adjusting and determining it, i. e., should consist of both a radio-frequency oscillator and a calibrated attenuator.

The General Radio Company has recently developed an instrument designed to meet these requirements. This outfit was developed to fulfill four conditions:

(1) A portable source equipped for use with external, unshielded batteries.



High-Voltage Plate-Supply Units

Two types of rectifier tubes are now generally available; the 280 type which provides full-wave rectification, and the 281 type, which provides half-wave rectification. The maximum transformer voltage permissible with the 280 type is 300 volts per anode, thus limiting its use to plate-supply units of low voltage output. The 281 type of tube, for which a final rating of 700 volts alternating current and 85 milliamperes output has been adopted, permits direct-current voltages of the order of 600 volts to be obtained from a single-wave rectifier, and of 700 volts with a full-wave connection.

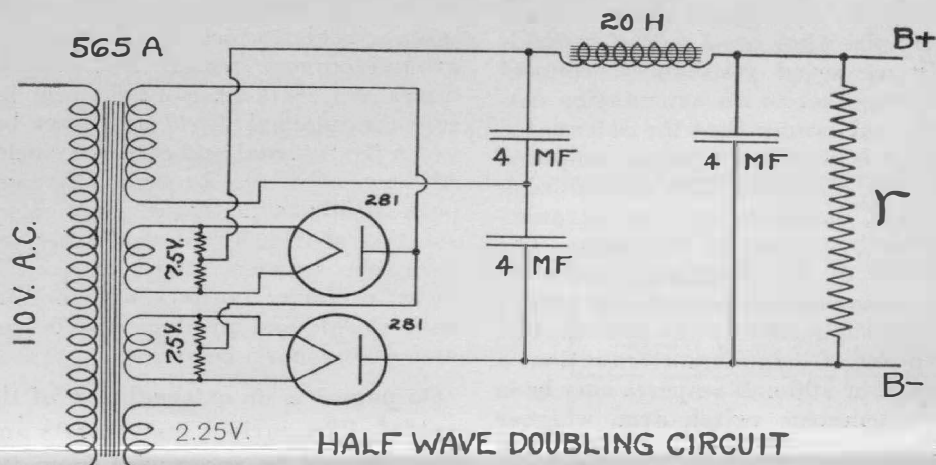

FIGURE 3

For voltages of the order of 1,000 to 1,500 volts the 281 type may be used in a voltage doubling connection, such as Figure 3 or Figure 4. In the half-wave system, as indicated in Figure 3, the voltage regulation is rather poor, but for low current the small amount of apparatus required

The first filter condensers must be able to withstand one half the load voltage. A condenser larger than 4 microfarads should not be used unless it is possible to close the filament circuit of the rectifier tubes before the high voltage is applied. The initial charging surge may overload the

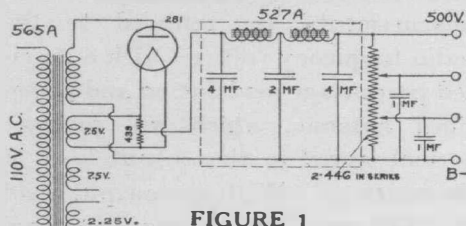

FIGURE 1

The filament of the 281 type of tube should be operated at, or slightly below, the rated voltage of 7.5 volts, and the voltage across the filament should never exceed 7.9 volts. In operating the 281 type, precaution should be taken to prevent an overload in respect to plate current. The short-circuiting of the rectifier output, such as occasioned through the failure of a filter condenser, will overload the filament and result in tube failure unless the current is turned off promptly. An indicating lamp may be placed in the circuit in series with each plate lead adjacent to the plate; if a 0.15 ampere, 6-volt dial lamp is used in this position it will glow at normal brilliancy when the full rated current of 160 milliamperes is flowing through each tube, utilizing, of course, the full-wave system. Excessive brilliancy of the lamp will indicate an overload of the tubes.

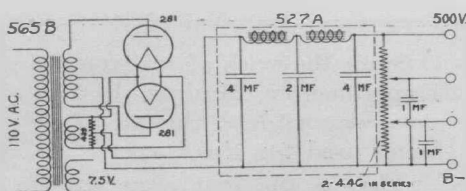

FIGURE 2

Typical connections for both half and full-wave systems, utilizing General Radio transformers and filters are shown in Figure 1 and Figure 2.

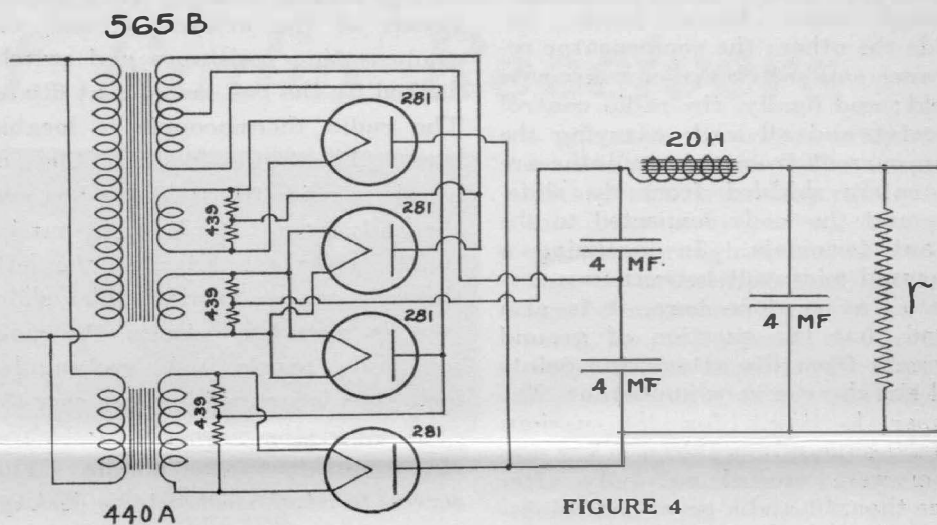

FIGURE 4

makes its use convenient. The regulation can be improved by using two additional 281 tubes in parallel with the tubes indicated.

The fixed resistance r should be 100,000 ohms, capable of carrying 20 milliamperes. If a milliammeter is connected in series with r it will give an approximate indication of the output voltage. The scale reading with a 100,000 resistor becomes 100 volts per milliamper.

Improved results are obtained with the full-wave voltage doubling circuit shown in Figure 4. The current output should not exceed 170 milliamperes. Three separate filament windings or transformers, insulated for the full output voltage, are required.

tubes and cause an arc if the filament is allowed to come up to temperature with the high plate voltage turned on.

High-voltage rectifier systems as described have many uses in conjunction with amateur transmitters and power amplifier equipment. Care should always be exercised in the construction of such devices on account of the high voltages. All connections should be in the form of heavily insulated wire and all exposed terminals should be protected by some sort of a guard or covering. Under all circumstances the current should be turned off before any adjustment is made.

(2) A range of output voltages from one microvolt up, with sufficient shielding to prevent the induction by stray fields of voltages comparable with the output voltage in any adjacent tuned circuit.

(3) An accuracy well within the consistency of measurements with highly stable receivers.

(4) The whole outfit to be reproducible by ordinary skilled shop labor.

A diagram of the circuits employed is shown in Figure 2. A single audio-oscillator tube is provided within the apparatus, for modulation at a fixed frequency of about 400 cycles. This is the frequency normally used for the most common measurements, sensitivity and selectivity. This oscillator comprises the tube shown at the left of the drawing, and the iron-core transformer tuned by a fixed condenser. This transformer feeds a modulation transformer through a resistance voltage divider marked **MODULATION CONTROL**. The audio voltage is impressed by the modulation transformer (of one-to-one ratio) upon the plate circuit of the radio-oscillator tube, and is measured by a thermal voltmeter comprising a resistance, a 30-ohm thermocouple, and a panel-mounting direct-current galvanometer shown at the lower part of the figure. If fidelity measurements are to be made, an external audio oscillator is necessary, for which provision is made with a third winding on the modulation transformer. This third winding is connected through a low-pass filter to exposed **EXTERNAL MODULATION** terminals on the main panel. This filter permits the use of an unshielded external audio oscillator, which may be positioned anywhere with respect to the signal generator and the receiver under test, and which may be connected to the signal generator through unshielded leads. The radio-oscillator tube has a "parallel-feed" plate circuit comprising the secondary of the modulation transformer and a radio-frequency choke coil in series with the positive plate-battery terminal and the plate. The tuned circuit of the radio oscillator consists of a "variometer" inductance which is connected by a metal belt to the variable tuning condenser, both being operated by a tuning dial on the front panel. The system maintains a nearly constant L/C ratio, and obviates the need of continual re-adjustment of the current as the tun-

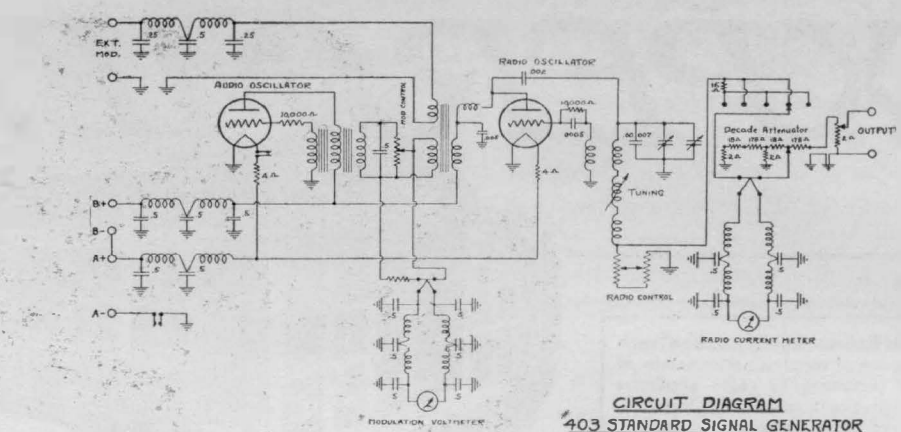

CIRCUIT DIAGRAM
403 STANDARD SIGNAL GENERATOR

ing is changed. A small variable condenser is provided in shunt with the main condenser for fine tuning adjustments. The tuned circuit is closed through an attenuator, which is bypassed to ground by a non-inductive variable resistance marked **RADIO CONTROL**. This resistance thus furnishes a means for adjusting the modulated radio-frequency current flowing into the attenuator. The current which passes into the attenuator is measured on a 4-ohm thermocouple connected through a twin two-section filter into a panel-type direct-current galvanometer which is exposed on the front panel of the outfit. The output end of the attenuator terminates in a 2-ohm non-inductive slide-wire which is connected to the output terminals on the front panel. This slide-wire consists of a short piece of No. 36 manganin wire stretched over a copper return path with an insulation strip between them 0.01 inch thick.

It will be noted, first, that all battery lines, the external modulation lines, and the lines of the two direct-current meters pass through filters. Filters are, of course, absolutely necessary if external batteries and modulation sources are to be allowed. Also, the advantage of being able to expose the current-measuring instruments without covering their dials with metallic screens is obvious.

The resistance attenuator is built of small non-inductive units in which no wire larger than No. 36 manganin is employed. It will be noted that no single resistance unit is larger than 178 ohms. This permits the use of the reversed-loop form of winding, which experience has shown to be more reliable as a radio-frequency voltage-drop resistance at 1500 kilocycles than the so-called bifilar or parallel-strand winding. Capacity effects in the reversed-loop winding would be important, even with wire

as small as No. 36 if high resistances were employed.

By using the slide-wire, then, we are enabled to employ a decade attenuator having only five steps. Using the values of resistance shown, the attenuation ratios at the various points on the attenuator from left to right on the diagram are respectively as follows: 10,000 to 1, 1,000 to 1, 100 to 1, 10 to 1, and 1 to 1. The slide-wire is provided with a calibrated scale of ten divisions. Thus, with the current through the **RADIO CURRENT** meter adjusted to a fixed value of 50 milliamperes, and the attenuator at the last point on the left on the panel a radio voltage of one microvolt is impressed between the output terminals with the slide-wire on its first scale division, and 10 microvolts with the slide-wire at maximum. The slide-wire scale is correspondingly multiplied in microvolts output at other points on the attenuator. The current may also be operated at twice the foregoing value without forcing the meter off scale, which provides a *maximum* output voltage of 200,000 microvolts.

The sliding-contact switch shown above the decade attenuator in the diagram is simply a device for throwing a fixed resistance of approximately 16 ohms in series with the attenuator on alternate points, in order to keep the total resistance in the radio-frequency circuit constant and to prevent current variations as the attenuator is shifted. This compensating resistance is controlled by a separate switch mounted on the same shaft with the attenuator switch, because it and its associated leads must be carefully shielded from the right-hand or low-voltage portion of the attenuator. The shielding of this attenuator is a delicate and rather complicated matter, brought about by the fact that, for convenience, we

(Continued on page 4)



(Continued from page 2)

ected to start with large radio-frequency currents. It may appear strange to the casual observer that we simply wind up a set of individually measured resistances, connect them together in an attenuation network, and assume that the attenuated voltage is equal to a value computed from the diagram. This procedure is justified, however, by the arrangement and shielding of the units. The features of the shielding system do not appear in the diagram. Its nature may be suggested by the fact that at the point of maximum attenuation, a current of 100 milliamperes may be in the attenuator switch arm, whereas a current of 10 micro-amperes and no more must flow into the slide-wire. This means that the net capacity between all conductors connected to the switch arm and all conductors connected to the last attenuator point (including the slide-wire) must be less than 0.5 micromicrofarad in order to reduce the capacity error to 2% at 200 meters. The units of the attenuator itself are distributed through three brass boxes, one inside the other; the compensator resistance and switch are in a separate shield; and finally, the radio control rheostat and all leads carrying the main current from the oscillator are separately shielded from the slide-wire and the leads connected to the output terminals. In localizing a measured microvolt between two terminals, as is done here, it is also found that the question of ground currents from the attenuator points and elsewhere is very important. The proper locations for the various ground connections shown in the diagram were worked out only after some thought and a great deal of discouraging experience.

Regarding the general shielding of the outfit, little has been said because it is more or less conventional. The radio and audio-oscillator circuits are mounted in a heavy copper box with a removable lid. The fittings are rather massive because the lid could not be soldered on and forgotten, as is readily done with laboratory equipment. This main internal shield is attached to a metal sub-panel, which is spaced by metal studs from the outside panel, also of metal. The outside panel is screwed tightly to a copper-lined cabinet and forms with it the outside shield. In some outfits of this sort it is better to insulate the internal assembly in its shield

from the outer shield; this is determined, in general, by the location of the attenuator and associated equipment with respect to the radio-oscillator circuit, which determines the ground current paths. The various filters are each distributed, part inside the internal shield and part between the internal and external shield. All controls are brought through both shields to the front panel on insulating shafts. Metal shafts are undesirable because they frequently make rubbing contacts with one or both shields and produce unexpected and disturbing phenomena.

On page 1 is an external view of the outfit. The various instruments and controls will be recognized from the description previously given. The output terminals are at the upper right-hand corner. The external dimensions of the cabinet are $19 \times 12\frac{3}{4} \times 9\frac{1}{2}$. At the bottom of the sub-panel is the main oscillator shield with cover screwed on. On top of this box are the separate shields of the attenuator and the compensating resistance and switch, flanked by the two instrument filters. The radio thermocouple is located here. The audio voltage thermocouple is inside the oscillator box and the leads from it are brought out into the voltmeter filter at the left, through copper braid. The slide-wire is mounted between the main and sub panels. A rectangular metal box is screwed in place over the attenuator, thermocouple, and rheostat assembly in the middle. This serves to stop electrostatic leakage from the exposed current-carrying leads over the top of the sub-panel around to the slide-wire terminals.

A word should be said as to the accuracy of the voltages supplied from the generator. Certain methods are available for checking the voltage ratios by comparison with an external voltage divider, and by comparison with known current ratios, also for checking the absolute values of voltage against other sources of a different nature. Thorough cross-checks and intercomparisons on this particular system indicate the following points: (1) The error in any ratio on the slide-wire or decade attenu-

ator is not greater than 3% at any frequency below 1500 kilocycles; (2) The error in the absolute value of the voltage between the generator terminals is not greater than 4% at any frequency and is probably much less for voltages above 10 microvolts.

The accepted practice in measuring and rating receivers is to impress the known voltage from the generator in series with the local antenna circuit and the input terminals of the receiver. The output of the receiver is equipped with a resistance load appropriate to the power tube or tubes which terminate the audio amplifier. A "normal signal" is specified for all receivers, usually 50 milliwatts. All measurements are referred to the radio-frequency voltage, with a specified percentage modulation and a specified antenna, which will produce normal signal in the output load of the receiver. With an output load of 2000 ohms, for example, normal signal corresponds to about 10 volts, which is a reasonable loud-speaker voltage. A simple "output meter" is required for all such measurements. It may be a vacuum-tube voltmeter or a thermal meter. Furthermore, sensitivity measurements are usually made with a modulation frequency of 400 cycles and 30% modulation. Suppose a receiver with specified antenna constants gives normal signal at 100 microvolts. This figure of 100 microvolts is a rational sensitivity rating for the receiver, because it means physically that if the receiver is fed from a 2-meter antenna having substantially the same effective inductance and capacity as that used in the measurement, a field strength of 50 microvolts per meter is required to provide entertainment.

Since the work of revising the Experimenter Mailing List is not yet complete, the old list is being used for this issue.

This is the last issue which will be mailed to those whose names have not been added to the list since July 1928, or who have not requested its continuance.